

# Understanding SCCR

Posted by [c3controls](#) May 10, 2018



## What is SCCR?

When it comes to industrial machinery, it's critical to ensure that electrical panels are designed and built with the proper SCCR to maintain the system, eliminate downtime and increase worker safety. The goal of this paper is to explain why it is important, and how to find the calculations needed.

SCCR stands for **Short-Circuit Current Rating**, which is defined in the 2017 NEC (National Electric Code), Article 100 as: *"The prospective symmetrical fault current at a nominal voltage to which an apparatus or system is able to be connected without sustaining damage exceeding defined acceptance criteria."*

In simpler terms, SCCR is the maximum short-circuit current an electrical component can safely withstand without causing a shock or fire hazard. In general, the SCCR rating for an electrical panel is based on understanding each electrical components SCCR rating in that panel. SCCR has become an increasingly important topic, regarding to the installation of industrial machinery and electrical panels at customer facilities.

## Why Is SCCR Important?

Because the SCCR represents the highest short-circuit fault current that equipment such as industrial control panels can safely withstand, exceeding the SCCR may cause catastrophic and violent equipment and component failure.

## 2017 NEC ARTICLE 670 INDUSTRIAL CONTROL PANELS

409.22 Short Circuit Current Rating.

(A) Installation. An industrial control panel shall not be installed where the available short-circuit exceeds its short-circuit rating as marked in accordance with 409.110(4)

Therefore, it's necessary to identify (calculate) the maximum short-circuit current that can be present where the industrial control panel or other equipment is installed. The available short-circuit current must be less than the marked SCCR of the industrial control panel to comply with the NEC.

It's important to understand short-circuit current ratings for industrial control panels. *Industrial control panel* is a general term that describes an assembly of two or more components that are enclosed. The assembly can be power, control or both, but doesn't include the controlled equipment.

In *UL 508A*, the *UL Standard for Safety for Industrial Control Panels and the National Electrical Code (NEC®)* the standard requires industrial control panels that contain power circuit components (supply main line power to loads such as motors, heating, lighting, appliances or receptacles) to be marked with an SCCR, previously referred to as a *withstand rating*.

As referenced in *UL 508A* and the *NEC*, industrial control panels that contain only control circuit components do not have to be marked with an SCCR.

If the industrial control panel contains a power circuit branch-circuit overcurrent protective device supplying the control circuit, then the SCCR must be marked based on the interruption rating of the overcurrent protective device.

## Power Circuit vs. Control Circuit

Prior to the release of the latest edition of *UL 508A*, Supplement SB dated December 20, 2013, SCCR applied only to the power circuit of a control panel. The power circuit supplies electricity to the workers that do the heavy lifting, powering large motors, for example. This is typically somewhere between 240VAC ~ 600VAC, 3 phase power. The control circuit is lower power, as low as 5 volts. As the name implies, it controls the operation of the power circuit, but is isolated from it. This is important so as to isolate the user from the high voltages and currents of the power circuit. Think of the control circuit as the brains and the power circuit as the brawn of a control panel.

## Calculating Short-Circuit Current Rating (SCCR)

Today, the majority of electrical components have the SCCR marked on the component itself by the manufacturer or a combination rating on the UL website. If the SCCR is not available, a default value can be assigned by referencing *Table SB4.1* in the *UL 508A* standard. Taking these values and the time needed to completely understand the circuit design being used, you realize that basically the component with the smallest SCCR in certain circuits determines the electrical panel SCCR rating.

### Step 1. Identify all the components in the power circuit. These include, but may not be limited to:

- Disconnect switches
- Circuit breakers
- Fuse holders
- Overload relays
- Motor controllers (contactors)
- Terminal blocks or power distribution blocks

### Step 2. Determine the SCCR value for all components in the power circuit.

- SCCR is usually marked on the component, combination ratings are available on the UL website, or with the manufacturer's instructions.
- If not available from the manufacturer, the SCCR value can be determined by using UL Table SB4.1 (see Appendix).

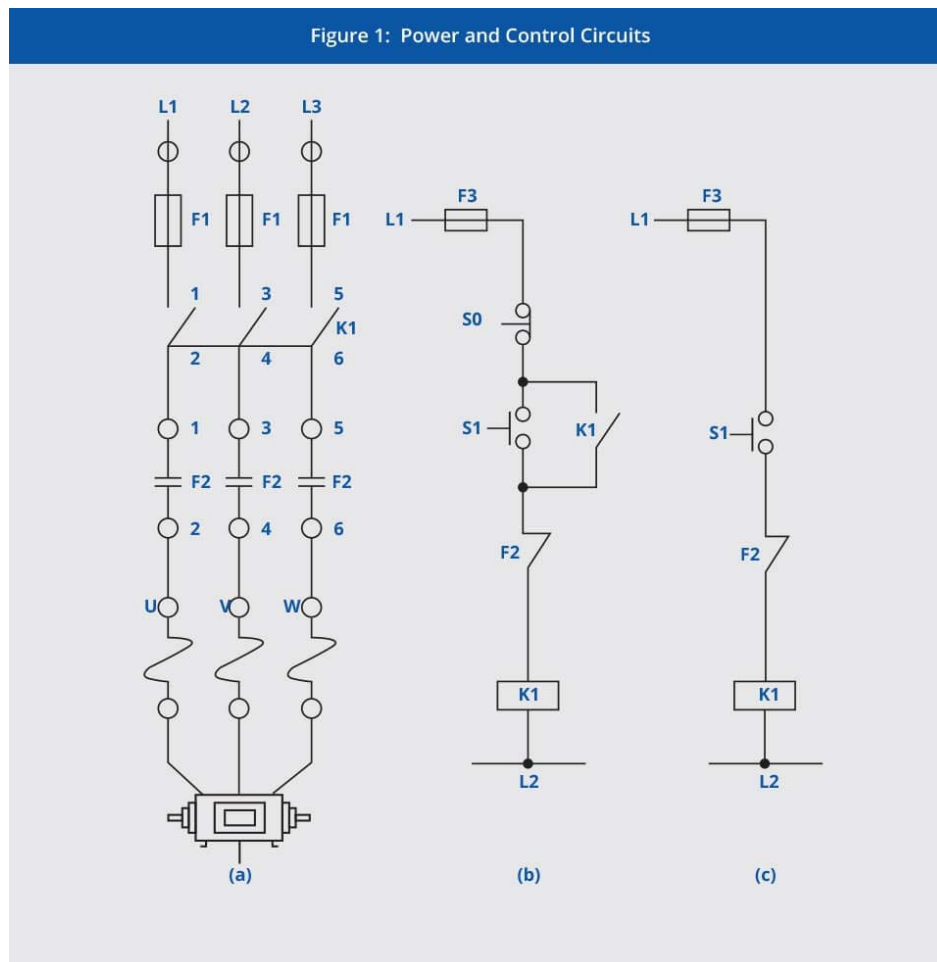

**Step 3. Determine the SCCR for each branch circuit.**

- The lowest component SCCR is the equivalent branch circuit SCCR

**Step 4. Determine the SCCR for the feeder circuit.**

**Step 5. Take in to account feeder circuit Over Current Protection Devices.**

**Step 6. Determine the lowest value for any component or branch circuit, this is the SCCR for the control panel.**

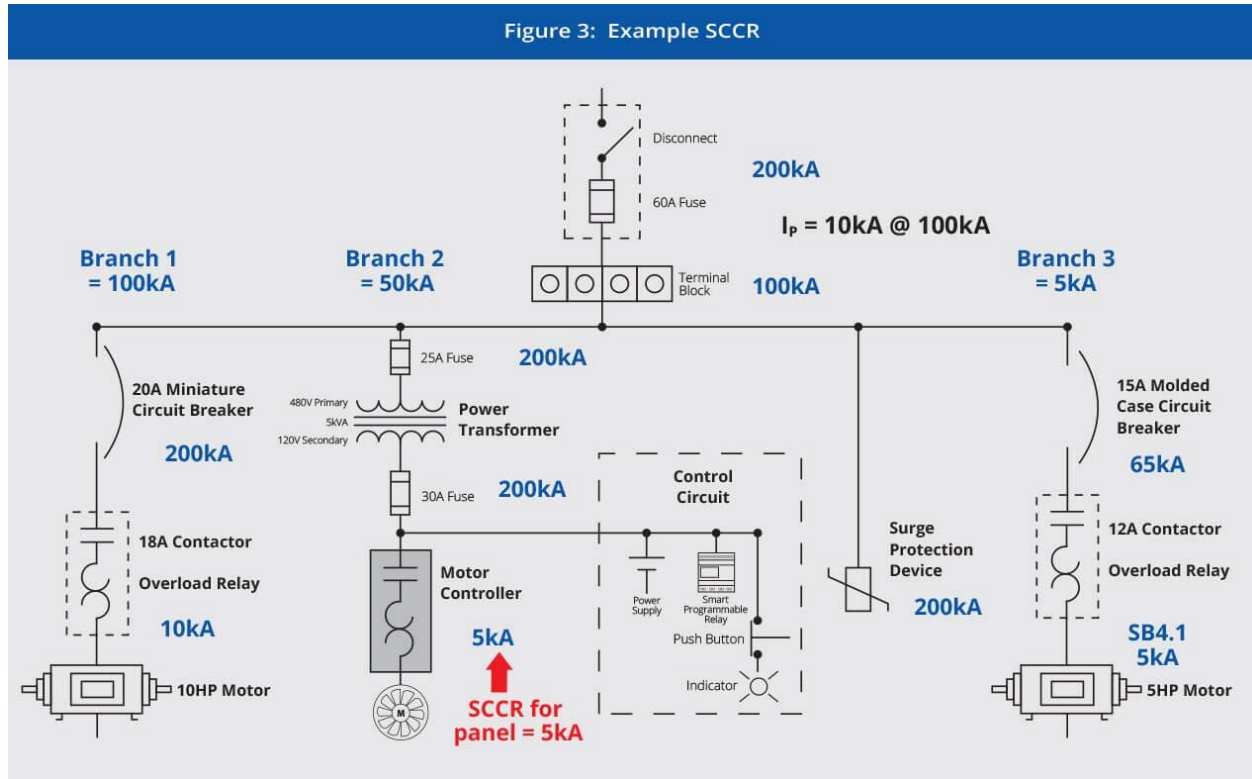

### Why SCCR is Important for Installation

Since the release of the 2005 NEC, industrial machinery electrical panels are required to be marked with an SCCR rating. Prior to this, panel manufacturers only had to supply the interrupting rating of the panel overcurrent protective device, or the amperage at which the main disconnect to the panel would “trip”.

This means that since the 2005 NEC release, industrial machinery electrical panel manufacturers had to start not only calculating SCCR ratings for their panels, but also understand the available short-circuit current that is supplied at the customer facility where installation of the panel will be.

If the available short-circuit current supplied to the panel is higher than the SCCR rating marked on the rating label of the panel, installation of the panel is prohibited by NEC, 670.5. This requires industrial machinery electrical panel installers to verify the available fault current at their customer facilities.

#### 2017 NEC ARTICLE 670 INDUSTRIAL MACHINERY

##### 670.5 Short Circuit Current Rating

(1) Industrial machinery shall not be installed where the available short-circuit current exceeds its short-circuit rating as marked in accordance with 670.3(A) (4).

## SCCR Compliance

To summarize, three things are important to remember when complying with SCCR ratings.

- The SCCR for the control panel is determined the lowest SCCR value for any component or branch circuit.
- The available fault current must be determined at the customer facility where the electrical panel will be installed. This determination can be done by the manufacturer or the installation contractor.
- The SCCR rating of the electrical panel must be equal to or greater than the available fault current determined.

Appendix  
Table SB4.1

Assumed Maximum Short Circuit Rating for Unmarked Components	
Component	Short Circuit Current Rating, kA
Bus Bars	10
Circuit Breaker (including GFCI type)	5
Current Meters	a
Current Shunt	10
Fuse Holder	10
<b>Industrial Control Equipment:</b>	
a. Auxiliary Devices (Overload Relay)	5
b. Switches (other than mercury tube type)	5
c. Mercury Tube Switches	5
Rated over 60 amperes or over 250 volts	3.5
Rated 250 volts or less, 60 amperes or less, and over 2 kVA Rated 250 volts or less and 2 kVA or less	1
<b>Motor controller (including combination motor controllers, float and pressure-operated motor controllers, power conversion equipment, and solid-state motor controllers) rated in horsepower (kW)<sup>d</sup></b>	
a. 0–50 (0–37.3)	5c
b. 51–200 (38–149)	10c
c. 201–400 (150–298)	18c
d. 401–600 (299–447)	30c
e. 601–900 (448–671)	42c
f. 901–1600 (672–1193)	85c
Meter socket base	10
Miniature or miscellaneous fuse	10b
Receptacle (GFCI type)	2
Receptacle (other than GFCI type)	10
Supplementary protector	0.2
Switch Unit	2
Terminal block or power distribution block	10
Multi-point interconnection power cable assembly	5
a. A short circuit current rating is not required when meter connected via a current transformer or current shunt. A directly connected current meter shall have a marked short circuit current rating. b. The use of a miniature fuse is limited to 125-volt circuits. c. Standard fault current rating for motor controller rated within specified horsepower range. d. Highest rated horsepower of motor controller.	

Source: UL Standard for Safety for Industrial Control Panels, UL 508A, Second Edition, December 20, 2013

**Disclaimer:**

The content provided in this white paper is intended solely for general information purposes and is provided with the understanding that the authors and publishers are not herein engaged in rendering engineering or other professional advice or services. The practice of engineering is driven by site-specific circumstances unique to each project.

Consequently, any use of this information should be done only in consultation with a qualified and licensed professional who can take into account all relevant factors and desired outcomes. The information in this white paper was posted with reasonable care and attention. However, it is possible that some information in these white papers is incomplete, incorrect, or inapplicable to particular circumstances or conditions. We do not accept liability for direct or indirect losses resulting from using, relying or acting upon information in this white paper.

There are post-order benefits as well. For example, order tracking is easier when it only requires only one call to one company. Support is streamlined and reliable as it's provided by a contact who directly supplies and understands all the components in your control panel.